

## CENTRIFUGAL IN-LINE FANS in metal



- Suitable for domestic, commercial or industrial applications.
- In-line configuration for simplified installation.
- High performances and pressure to overcome the resistance caused by long length ducting.
- Can be used with flexible and rigid ducting.
- Heavy-gauge, spun steel housing with baked epoxy finish inside and outside.
- External junction box contains connections.
- Backward curved blades to ensure the lowest possible sound and to develop ample static pressure.
- Durable external rotor motor provided with thermal reset overload protection.
- Ball bearing motor, permanently lubricated for maintenance-free operation and continuous running.
- Fan and motor assembly balanced for quiet and vibration-free operation.
- Variable speed controllable.
- Fans comply with EN 60335-2-80, EC Low Voltage Directive 73/23 - 93/68 and EC Directive EMC 89/336.



IPX4



### DIMENSIONS (mm)

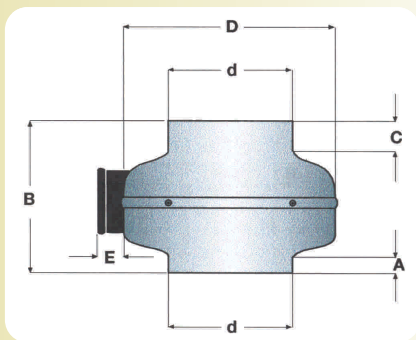

Tipo	A	B	C	ø D	ø d	E	Kg.
AXC 100 A	12	215	24	245	98	38	3
AXC 100 B	12	215	24	245	98	38	3
AXC 125 A	11	214	24	245	122	38	3
AXC 125 B	11	214	24	245	122	38	3
AXC 150 A	21	216	23	245	147	38	3
AXC 150 B	22	230	22	333	148	38	5
AXC 160 A	24	215	24	245	157	38	3
AXC 160 B	21	230	22	333	158	38	5
AXC 200 A	22	230	27	333	198	38	5
AXC 200 B	22	230	27	333	198	38	5
AXC 250	22	230	35	333	248	38	5
AXC 315 A	30	297	52	404	314	38	8
AXC 315 B	30	308	52	404	314	38	9
AXC 355 A	44	400	50	484	355	38	11,8
AXC 355 B	44	400	50	484	355	38	14,1

### APPLICATIONS

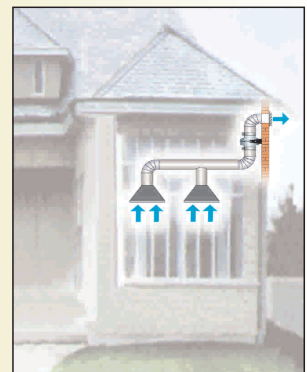
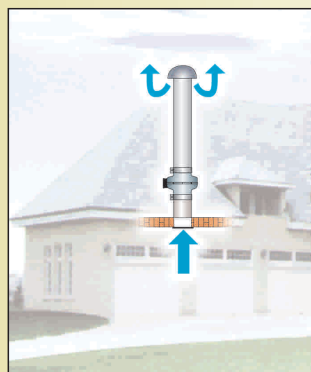

## SPECIFICATION

### AXC 100A - 100B

Product code	RPM	m <sup>3</sup> /h max	Pa max	dB(A)* @ 3 m	W	A	V Hz	Speed controller	Type
AXC 100 A	1990	195	350	40	64	0,30	230/50-60	RVN or RVS	AXC 1
AXC 100 B	2530	250	380	45	64	0,30	230/50-60	RVN or RVS	AXC 1

\*3 m 20 m<sup>2</sup> Sabine

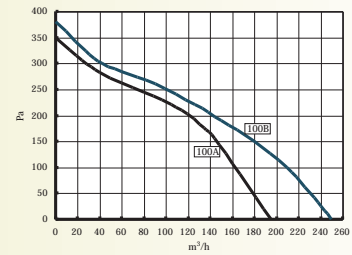

### AXC 125A - 125B

Product code	RPM	m <sup>3</sup> /h max	Pa max	dB(A)* @ 3 m	W	A	V Hz	Speed controller	Type
AXC 125 A	1700	245	310	42	74	0,34	230/50-60	RVN or RVS	AXC 1
AXC 125 B	2400	325	340	45	63	0,30	230/50-60	RVN or RVS	AXC 1

\*3 m 20 m<sup>2</sup> Sabine

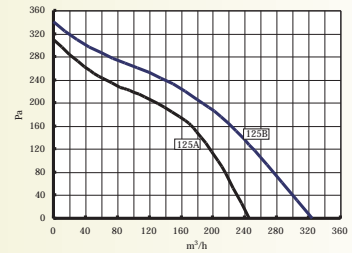

### AXC 150A - 150B

Product code	RPM	m <sup>3</sup> /h max	Pa max	dB(A)* @ 3 m	W	A	V Hz	Speed controller	Type
AXC 150 A	2470	400	310	46	65	0,30	230/50-60	RVN or RVS	AXC 1
AXC 150 B	2450	530	420	45	78	0,40	230/50-60	RVN or RVS	AXC 2

\*3 m 20 m<sup>2</sup> Sabine

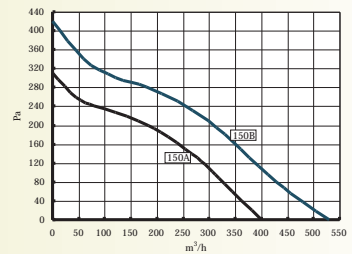

### AXC 160A - 160B

Product code	RPM	m <sup>3</sup> /h max	Pa max	dB(A)* @ 3 m	W	A	V Hz	Speed controller	Type
AXC 160 A	2395	440	330	46	68	0,30	230/50-60	RVN or RVS	AXC 1
AXC 160 B	2550	700	420	47	112	0,50	230/50-60	RVS-1	AXC 2

\*3 m 20 m<sup>2</sup> Sabine

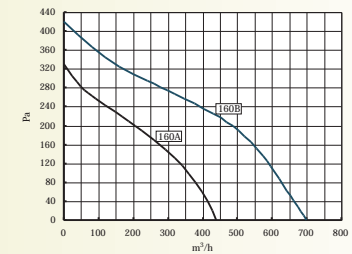

### AXC 200A - 200B

Product code	RPM	m <sup>3</sup> /h max	Pa max	dB(A)* @ 3 m	W	A	V Hz	Speed controller	Type
AXC 200 A	2450	750	350	50	80	0,40	230/50-60	RVN or RVS	AXC 2
AXC 200 B	2700	980	580	50	152	0,70	230/50-60	RVN or RVS-1	AXC 2

\*3 m 20 m<sup>2</sup> Sabine

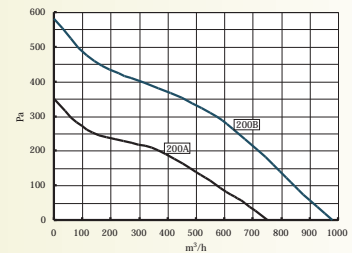

### AXC 250 - 315A - 315B

Product code	RPM	m <sup>3</sup> /h max	Pa max	dB(A)* @ 3 m	W	A	V Hz	Speed controller	Type
AXC 250	2550	1120	570	53	173	0,78	230/50-60	RVN or RVS-1	AXC 2
AXC 315 A	2645	1400	580	54	174	0,80	230/50-60	RVN or RVS-1	AXC 3
AXC 315 B	2630	1850	700	59	297	1,30	230/50	RVS-1	AXC 3

\*3 m 20 m<sup>2</sup> Sabine

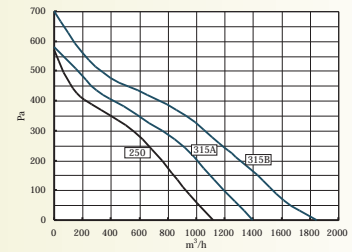

### AXC 355A - 355B

Product code	RPM	m <sup>3</sup> /h max	Pa max	dB(A)* @ 3 m	W	A	V Hz	Speed controller	Type
AXC 355 A 4 pole motor	1330	2200	349	57	248	1,12	230/50	RVN or RVS-1	AXC 4
AXC 355 B 2 pole motor	2560	2350	902	77	630	2,82	230/50	RV1	AXC 4

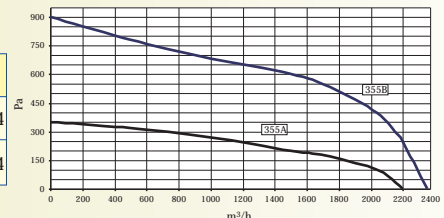

## CURVES